

REVISIONS				
ZONE	REV.	DESCRIPTION	DATE	APPROVED
	0	INITIAL RELEASE.	03/09/07	JCW
B3	1	ADDED 4-40 RADIAL TAPPED HOLE (3X).	06/20/07	JCW

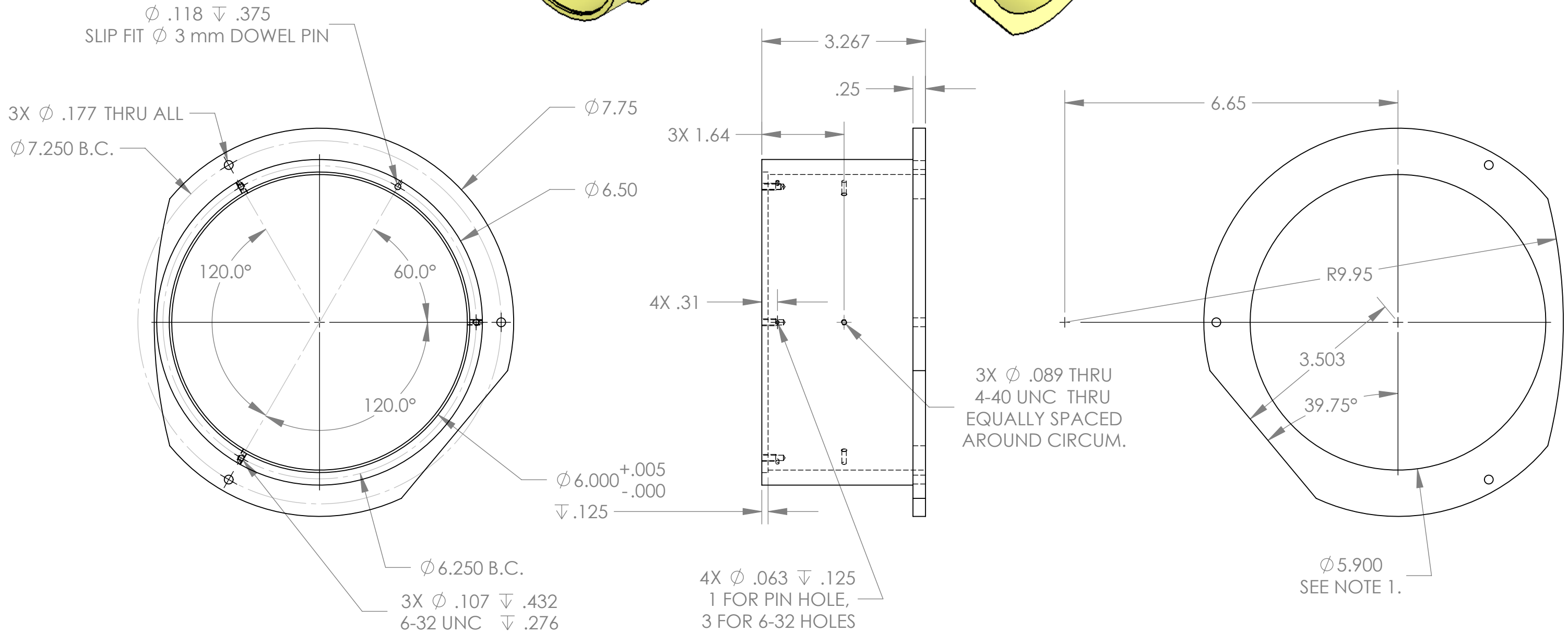
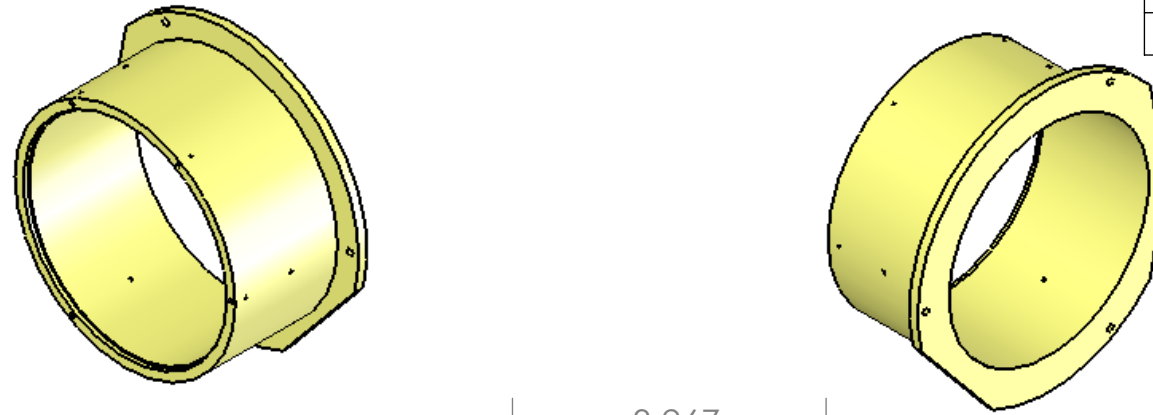

NOTES:
1. MINOR DIAMETER OF 60° SHARP VEE THREAD, .043" PITCH, TAPPED THRU.

UNLESS OTHERWISE SPECIFIED DIMENSIONS
ARE IN INCHES, REMOVE BURRS AND
BREAK SHARP EDGES 0.005-0.010

TOLERANCES: .XX±.010 .XXX±.005
ANGLES ±0.5° UNLESS NOTED,
ALL SURFACES 64 UNLESS NOTED

MATERIAL: 6061-T6 ALUM
QTY: 1



NAME: _____ INIT. _____ DATE: _____
DRAWN: SCP SCP 06/15/07
CHECKED: JCW JCW 06/20/07
APPROVED: _____
FABRICATED: _____

TRIPLESPEC

Cornell University
Center for Radiophysics and Space Research - Ithaca, NY 14853

TITLE: OAP1 MOUNT BAFFLE, APO

SIZE: B DRAWING # TRDOP46 REV 1

SCALE: 1:2 DATE: 6/25/2007 SHEET 1 OF 1

FILE: TRDOP46 OAP1 Mount Baffle, APO