

F9J " NC B9		89G7 F DHC B		
\$		8jā W.Ub[Y.:") \$ tē; "(-	%\$#&+ #&\$ \$*	7 <
%	7 &	8jā W.Ub[Y.:" , tē "" +	%&#%/(#&\$ \$*	7 <
	7 (8jā W.Ub[Y.:" , tē "" +		
	7)	8jā W.Ub[Y.:" ff* &) tē ff* %* tē		
	7 *	8jā W.Ub[Y.:" +) && tē +) %		
	8)	8jā W.Ub[Yg; , %&) tē ; %& z UbX** , +) tē** , **		

8
7
6
5

8
7
6
5

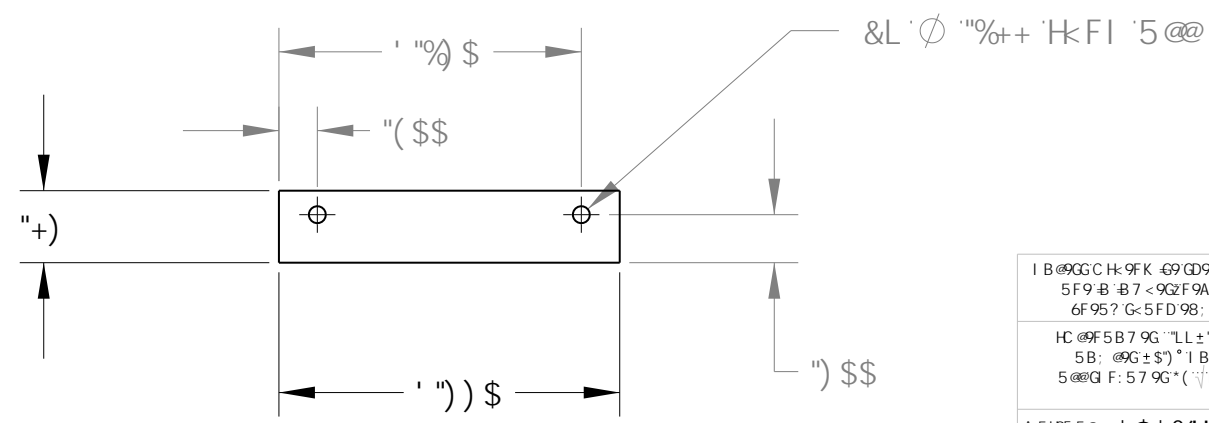
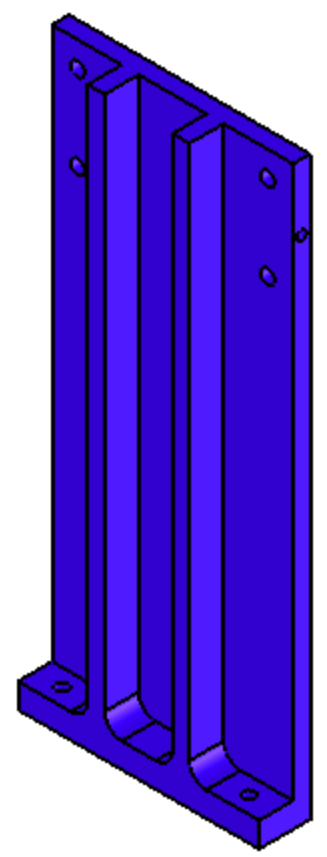
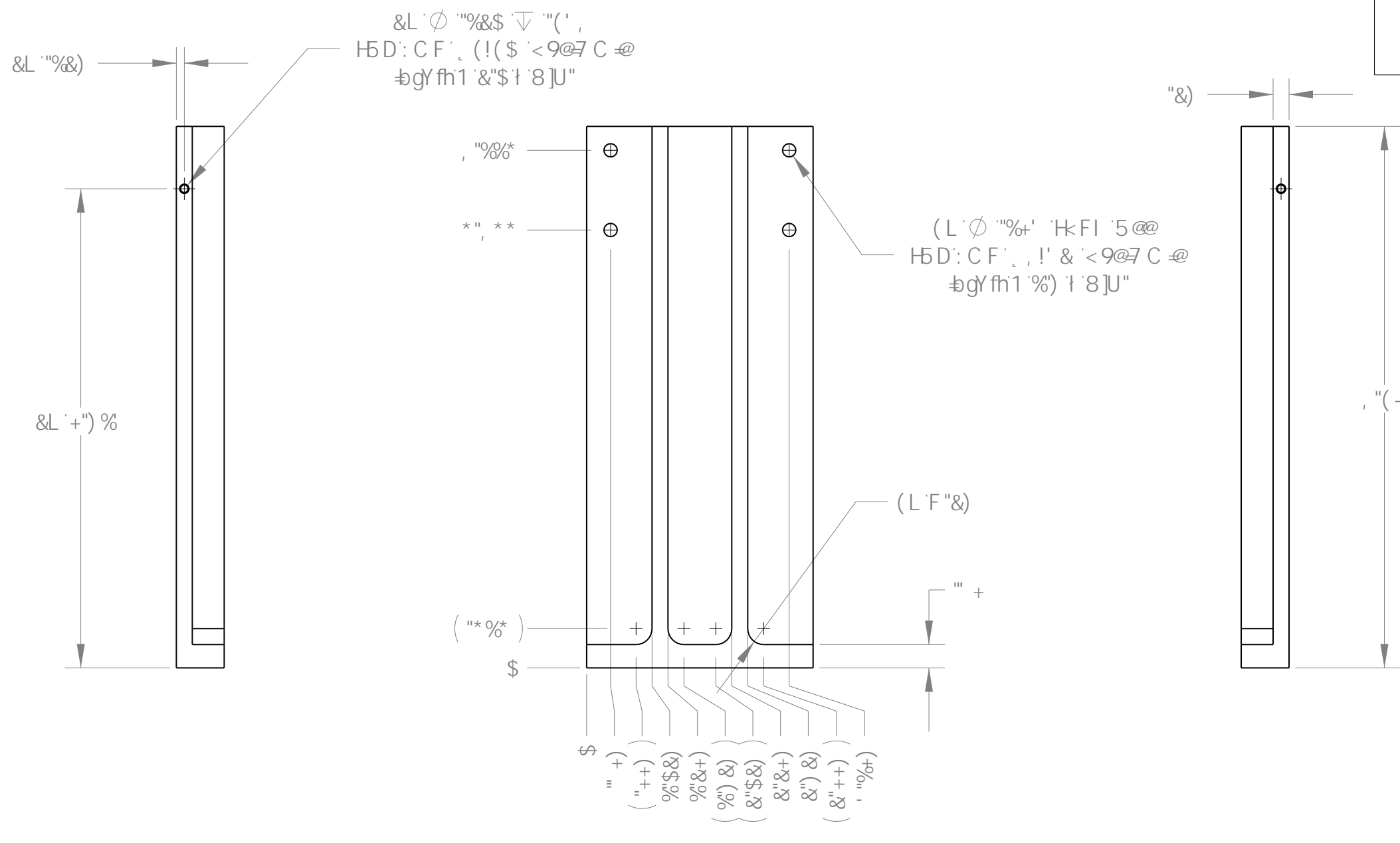

I B@9GCH:9FK 49D97 + 98 8 A 9BGC BG 5F9 B B7 < 9G2F9A CJ 96I FG5B8 6F95? G< 5FD 98: 9G\$ \$S) I\$ \$S\$		HF D@9GD97		Eqtpgm'Wpkgtukv Egpgvt' hqt' Tcf kqr j { uku' tpf 'Ur ceg' Tgugctej ' /' Kij cec. 'P['36: 75	
HC @9F5B7 9G "LL± "%\$ "LLL± "\$S) 5B: @9G± "\$) * I B@9GBC H98 2 5@@Q F: 57 9G* (" I B@9GBC H98	B5A 9.	B#H	85H9.	H#09 . &bX 'C 5D' 6F579	
A 5H9F 5@ * \$* %H* '5@ E HM*	8F5K B.	G7 D	%&#%/(# \$*	GAN. 6 8F5K B: . HF8CD, + F9J %	
	7 < 97 ? 98.	7 <	%&#%/(# \$*	G7 5 @. %& 85H9. %&#%/(#&\$ \$* G< 99H% C : %	
	5DDFC J 98.				
	: 56F 7 5H98.				
	: @9. HF8CD, + &B8 C 5D' 6F579				