

#DA BC "	D5FHBI A 69F #B5A 9	E HM
%	HF8CD+(5'7c''6UZY' H VY	%
&	HF8CD+(6'7c''6UZY' D'UH	%

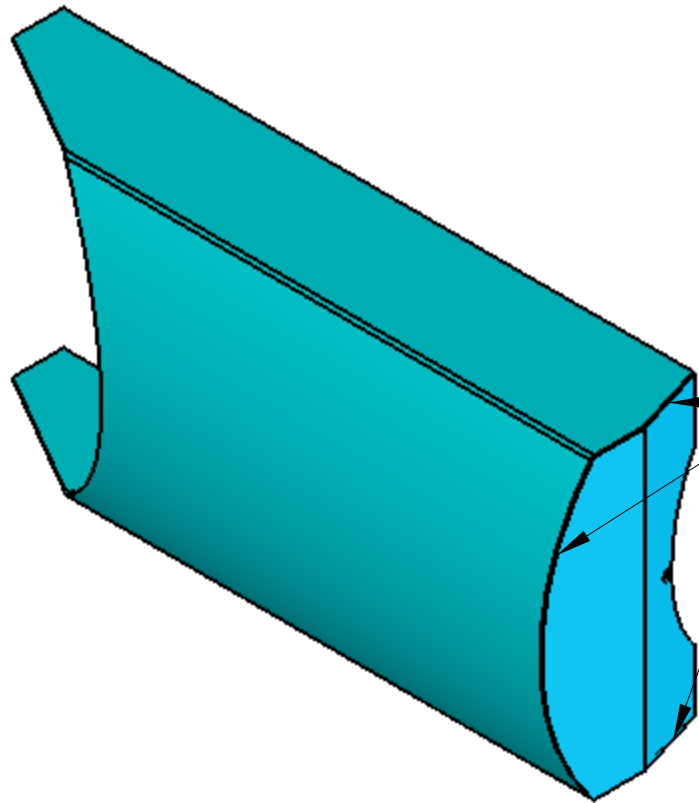

'K 9@8 'G95A G'

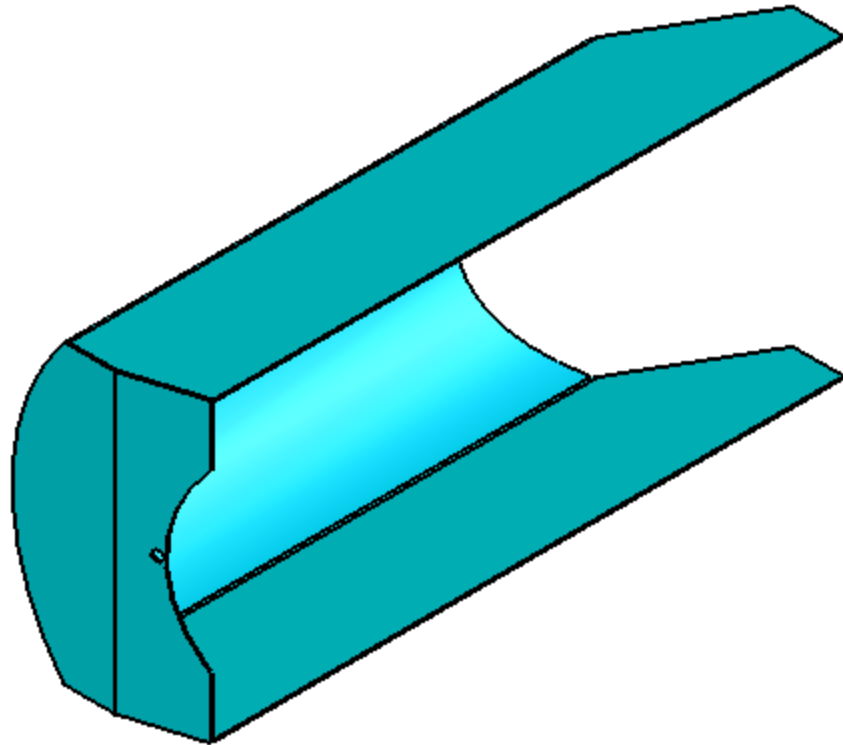
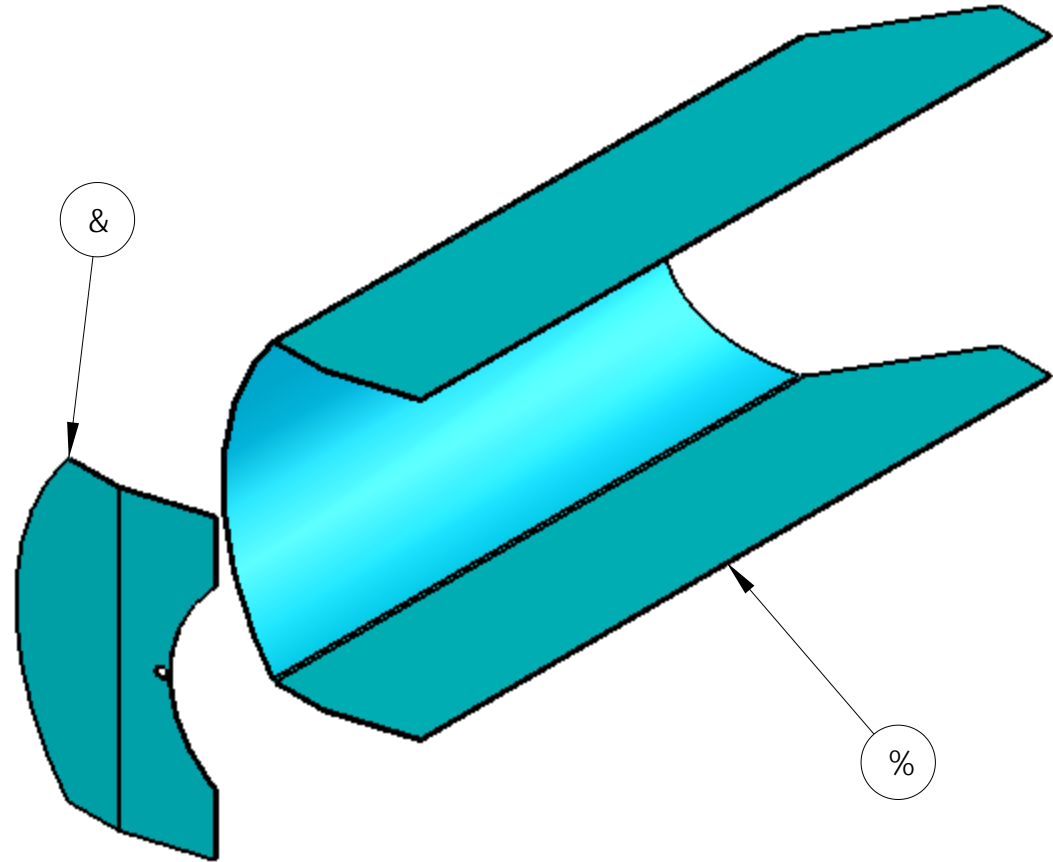

I B@9GCH:9FK 49 CD97 + 98 8 A 9BGC BG
5F9 B B7 <9GF9A CJ 9 6I FG5B8
6F95? G<5FD 98: 9G\$'\$S) I\$'\$S%\$

HC @F5B7 9G "LL±"%"\$ "LLL±"\$\$)
5B: @9G±\$)* I B@9GBC H98 2
5@@QI F: 57 9G*("I B@9GBC H98

A 5H9F 5@
E HM'

B5A 9.	B#H	85H9.
8F5K B.	G7 D	%/#\$' #S*
7 < 97 ? 98.	7 <	%/#\$' #S*
5DDFC J 98.		
: 56F 7 5H98.		

HF D@9GD97

Egpgt'hqt'Tcf kqrj { uku'cpf 'Ur ceg'Tgugctej ' /'Kj cec.'P['36: 75

7 C @65:: @'K 9@8 98

6 HF8CD+(F9J \$

G7 5 @. %& 85H9. %/# #&\$S* G< 99H% C: %