

BC H9. '1 G9%# &'5@ A 'G<99H'

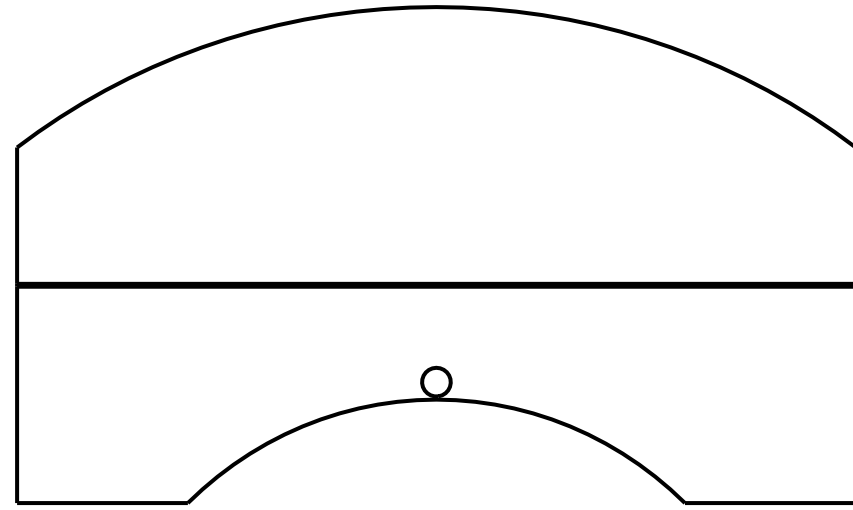

69B8 'F58 ± GF "\$&

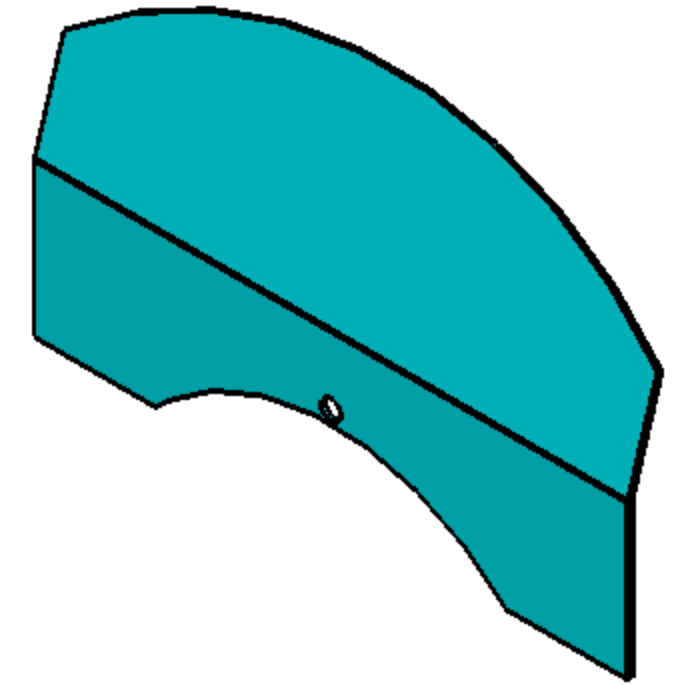
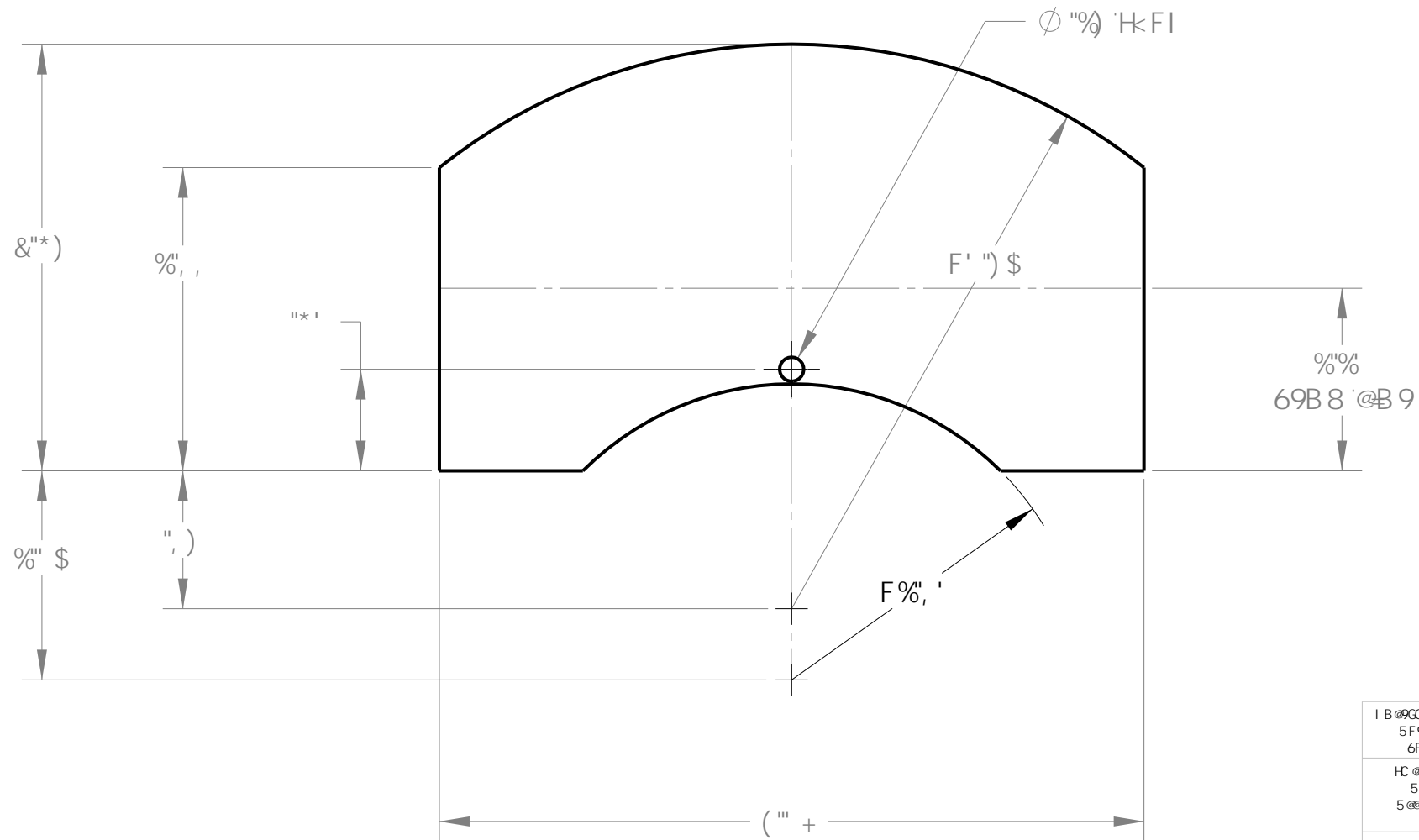
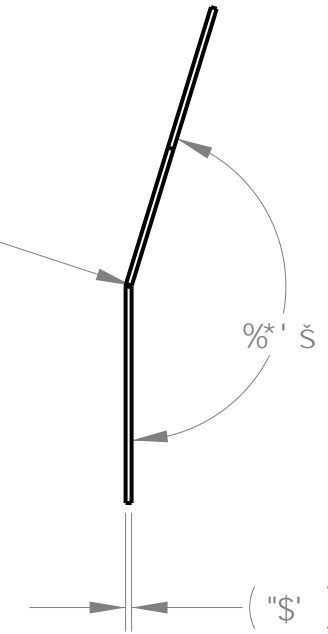

I B@9GC H:9FK 49 CD97 ± 98 8 A 9BGC BG 5F9 B B7 <9GF9A CJ 9 6I FG5B8 6F95? G<5FD 98: 9G\$"\$) I\$"\$%\$		HF D@9GD97		Eqtpgm'Wpkgtukv Egpgt'hqt'Tcf kqr j {ukeu'cpf 'Urceg'Tgugctej ' /'Kj cec.'P[ '36: 75	
HC @9F5B7 9G "LL±"\$%\$ "LLL±"\$)\$ 5B: @9G±"\$) *1 B@9GBC H982 5@@QI F: 57 9G*( "1 B@9GBC H98		B5A 9.	B#H	85H9.	H#09. · 7 C @65:: @9'D@5 H9
A 5H9F-5@		8F5K B.	G7 D	%@#\$' #S\$*	GAN. 6 8F5K B: H8CD+(6 F9J \$
'\$\$' '5@ E HM'		7 <97?98.	7 <	%@#\$' #S\$*	G7 5 @. %%
		5DDFC J 98.			85H9. %@/# #&\$S\$*
		: 56F 7 5H98.			G<99H% C: %
		: @9. HF8CD+(6 7 c'6UZY DUH			