

REVISIONS				
ZONE	REV.	DESCRIPTION	DATE	APPROVED
	0	INITIAL RELEASE.	05/15/07	JCW

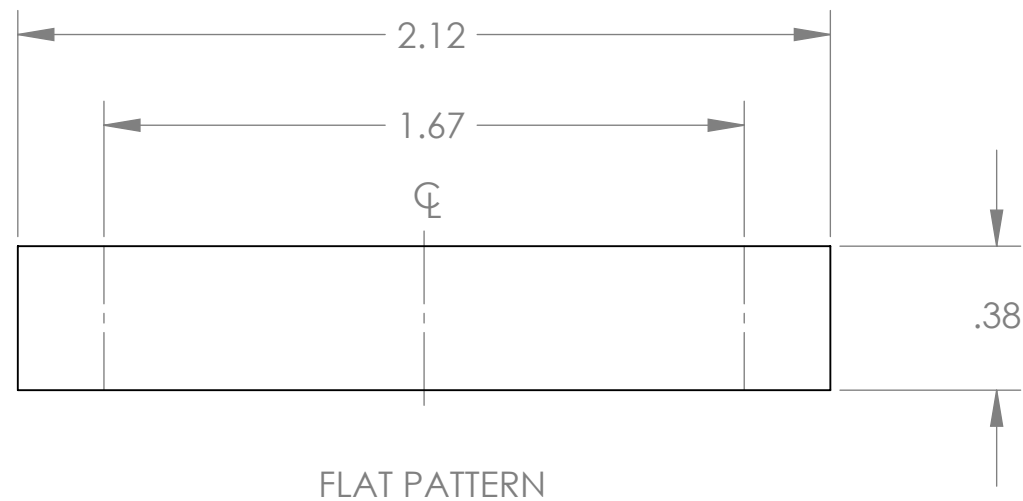

UNLESS OTHERWISE SPECIFIED DIMENSIONS ARE IN INCHES, REMOVE BURRS AND BREAK SHARP EDGES 0.005-0.010
 TOLERANCES: .XX ± .010 .XXX ± .005
 ANGLES ± 0.5° UNLESS NOTED,
 ALL SURFACES 64 UNLESS NOTED

MATERIAL: 3003 ALUM
 QTY: 6

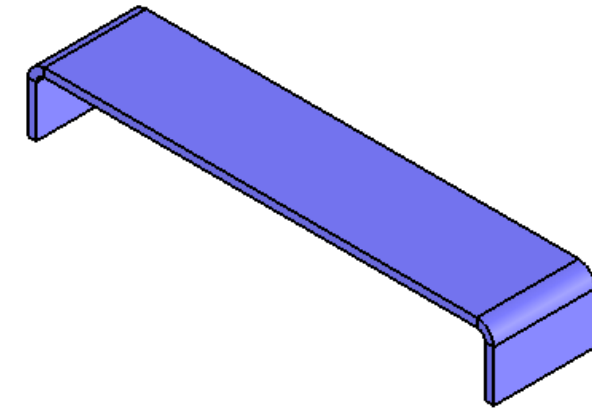
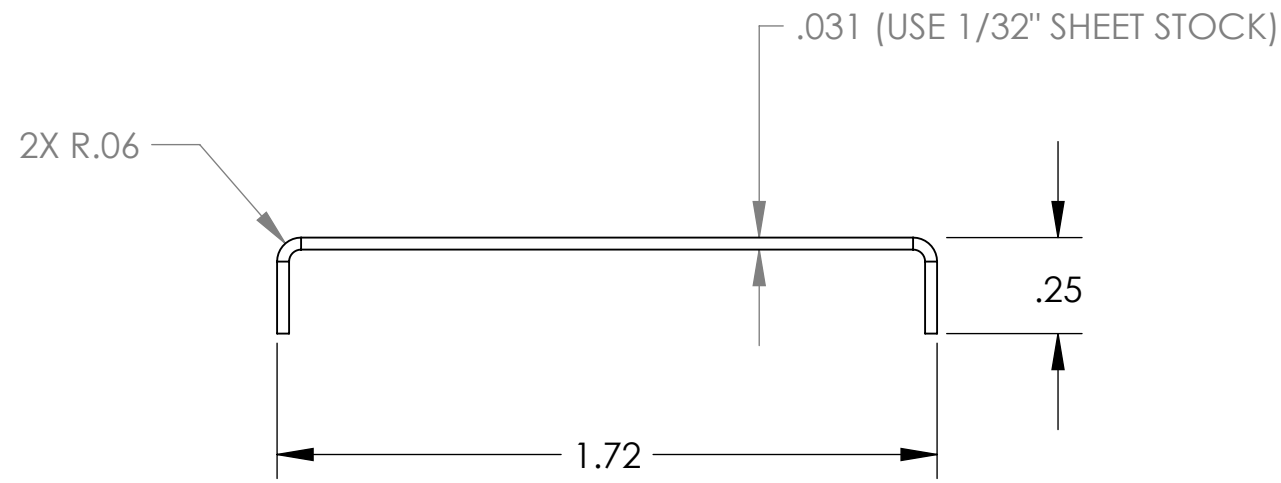

NAME: _____ INIT: _____ DATE: _____
 DRAWN: _____ SCP 05/09/07
 CHECKED: _____ JCW 05/15/07
 APPROVED: _____
 FABRICATED: _____

FILE: TRDOP96C SBB Stringer

TRIPLESPEC

Cornell University
 Center for Radiophysics and Space Research - Ithaca, NY 14853

TITLE: SBB STRINGER

SIZE: B DRAWING # TRDOP96C REV 0

SCALE: 2:1 DATE: 5/21/2007 SHEET 1 OF 1