

UNLESS OTHERWISE SPECIFIED DIMENSIONS
ARE IN INCHES, REMOVE BURRS AND
BREAK SHARP EDGES 0.005-0.010
TOLERANCES: .XX \pm .010 .XXX \pm .005
ANGLES \pm 0.5° UNLESS NOTED,
ALL SURFACES 64 UNLESS NOTED

MATERIAL:
QNTY: 1



TRIPLESPEC

NAME:	INIT.	DATE:
DRAWN:	CH	
CHECKED:		
APPROVED:		
FABRICATED:		

FILE: TRD3V032 APO Small Cover 4

Cornell University
Center for Radiophysics and Space Research - Ithaca, NY 14853

TITLE: APO SMALL COVER 4

SIZE: B DRAWING # TRD3V032 REV 0

SCALE: 1:2 DATE: 8/16/2006 SHEET 1 OF 2

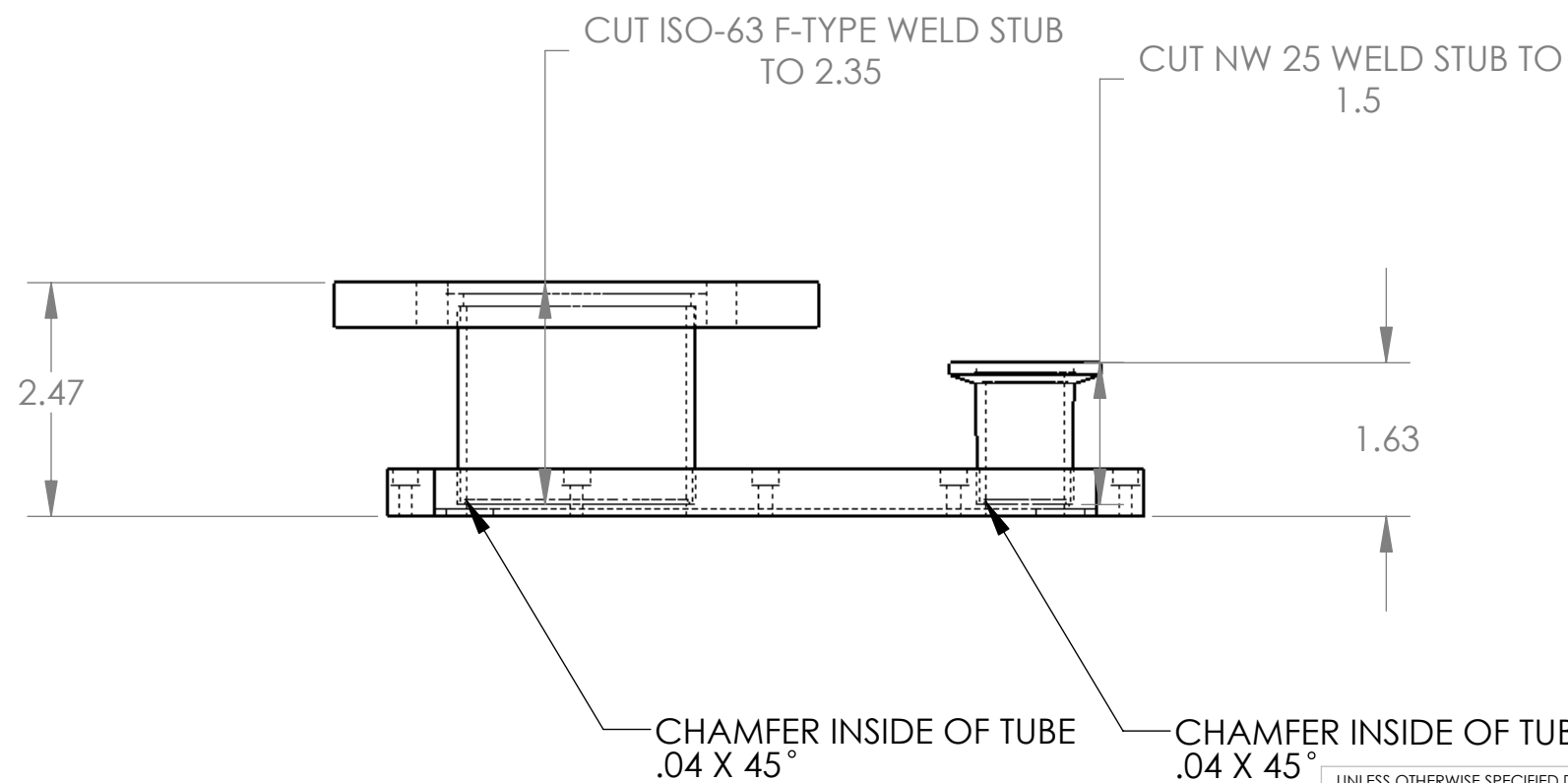
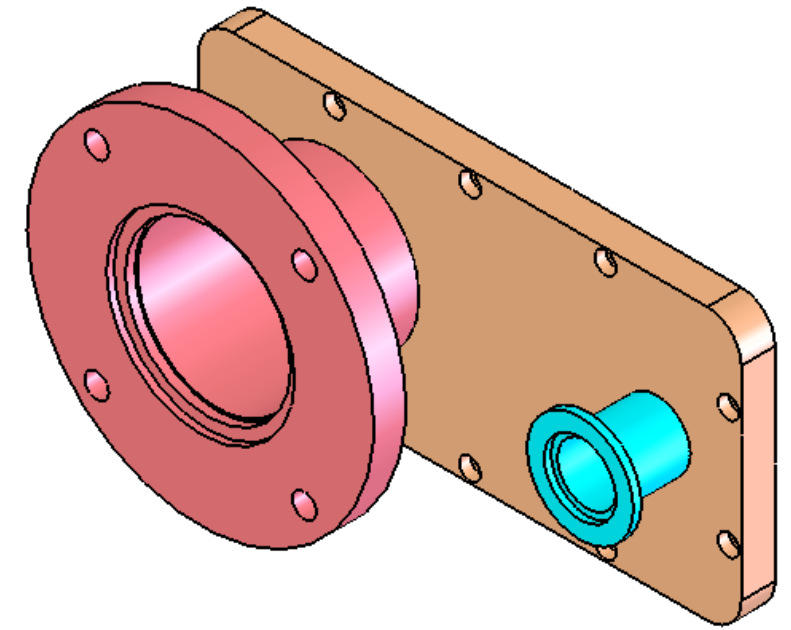
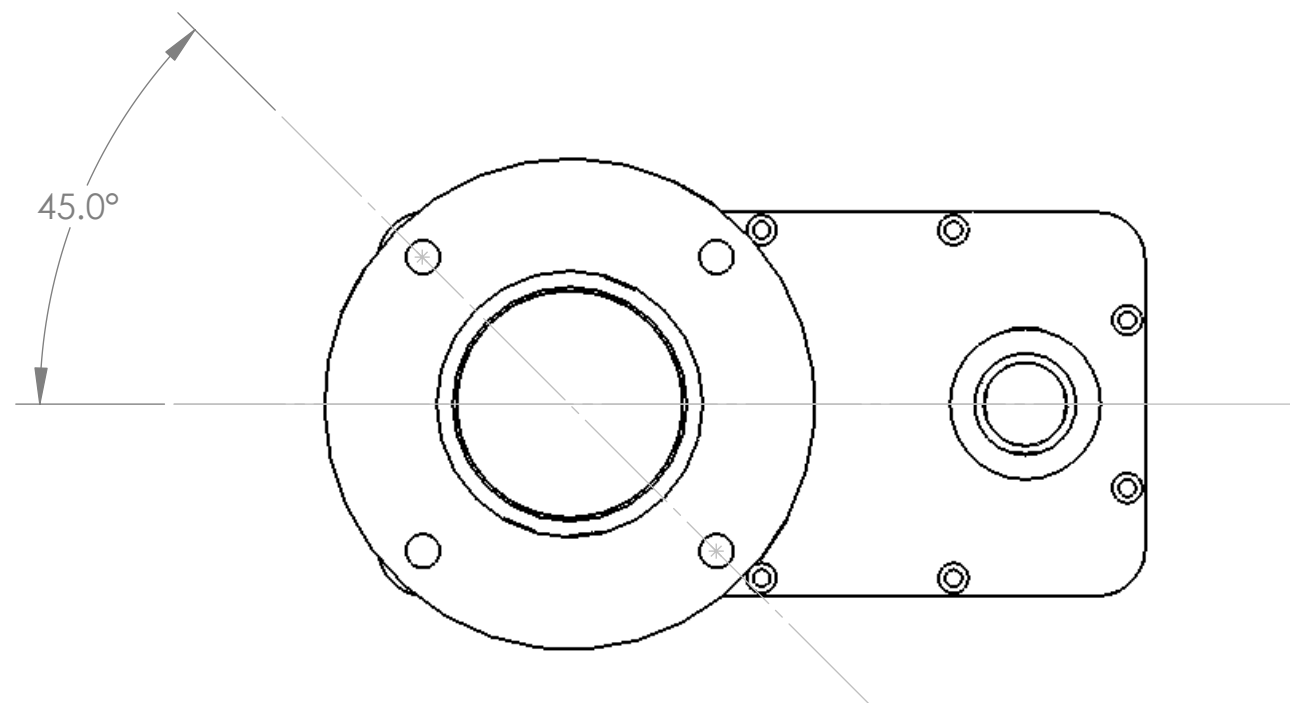

UNLESS OTHERWISE SPECIFIED DIMENSIONS ARE IN INCHES, REMOVE BURRS AND BREAK SHARP EDGES 0.005-0.010
 TOLERANCES: .XX±.010 .XXX±.005
 ANGLES ±0.5° UNLESS NOTED, ALL SURFACES 64 UNLESS NOTED

MATERIAL:
 QNTY: 1

NAME:
 INIT. CH
 DATE:
 DRAWN:
 CHECKED:
 APPROVED:
 FABRICATED:
 FILE: TRD3V032 APO Small Cover 4

TRIPLESPEC

Cornell University
 Center for Radiophysics and Space Research - Ithaca, NY 14853

TITLE: APO SMALL COVER 4 ASSEM.

SIZE: B DRAWING # TRD3V032 REV 0

SCALE: 1:2 DATE: 8/16/2006 SHEET 2 OF 2