

REVISIONS				
REV.	ZONE	DESCRIPTION	DATE	APPROVED
0		Initial Release.	8/31/2004	

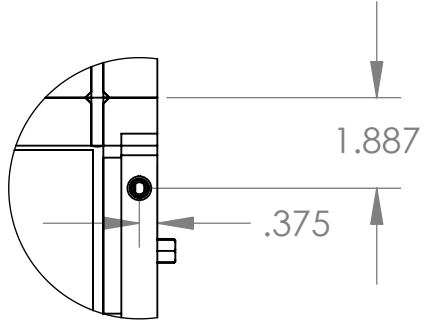

DETAIL E
SCALE 1 : 4

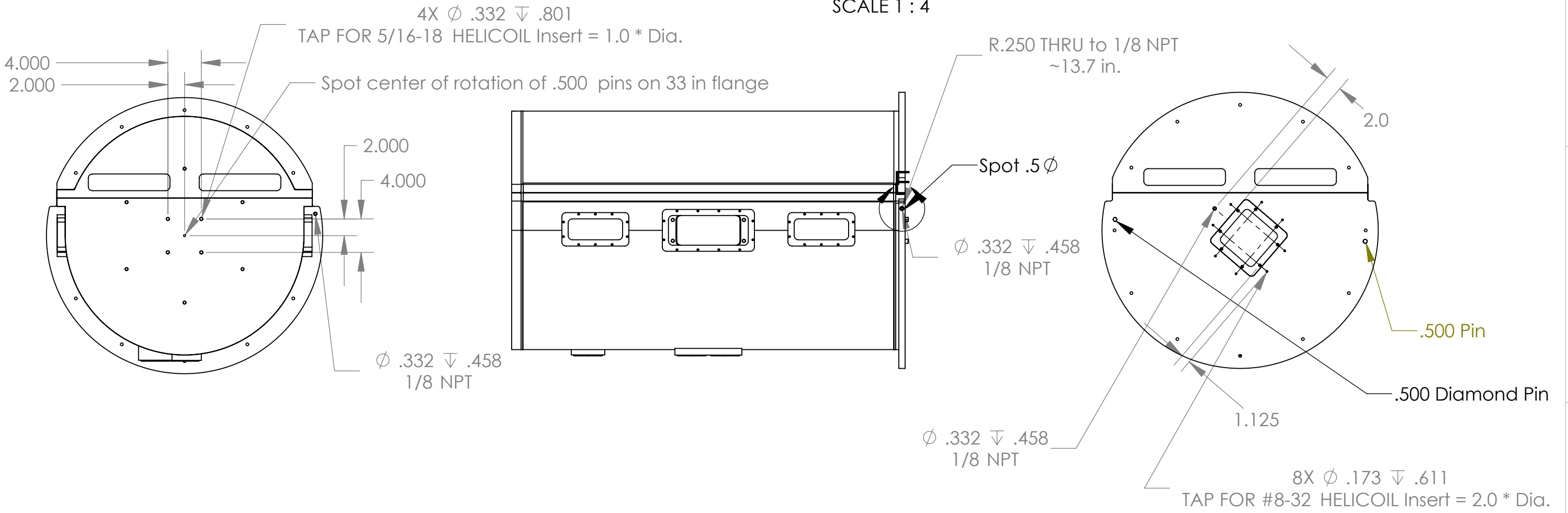

UNLESS OTHERWISE SPECIFIED DIMENSIONS ARE IN INCHES, REMOVE BURRS AND BREAK SHARP EDGES 0.005-0.010
 TOLERANCES: .XX±.010 .XXX±.005
 ANGLES ±0.5° UNLESS NOTED, ALL SURFACES 64 UNLESS NOTED
 MATERIAL:

NAME: INIT. DATE: TITLE:
 DRAWN: CH
 CHECKED:
 APPROVED:
 FABRICATED:
 FILE: TRD3VA03 Final Tank

TRIPLESPEC Cornell University
 Center for Radiophysics and Space Research - Ithaca, NY 14853

TITLE: Final Tank

SIZE: B DRAWING # TRD3VA03 REV 0

SCALE: 1:8 DATE: 7/7/2006 SHEET 1 OF 1