

REVISIONS				
ZONE	REV.	DESCRIPTION	DATE	APPROVED
	0	INITIAL RELEASE.	04/02/07	JCW
	1	REMOVED POCKET FOR LYOT STOP, MOVED PINS TO OPPOSITE SIDE, REMOVED C-BORE, ADDED C-SINK, REDUCED OVERALL LENGTH, INCREASE OVERALL HEIGHT, CHANGED MATERIAL TO 303 SS.	05/10/07	CH

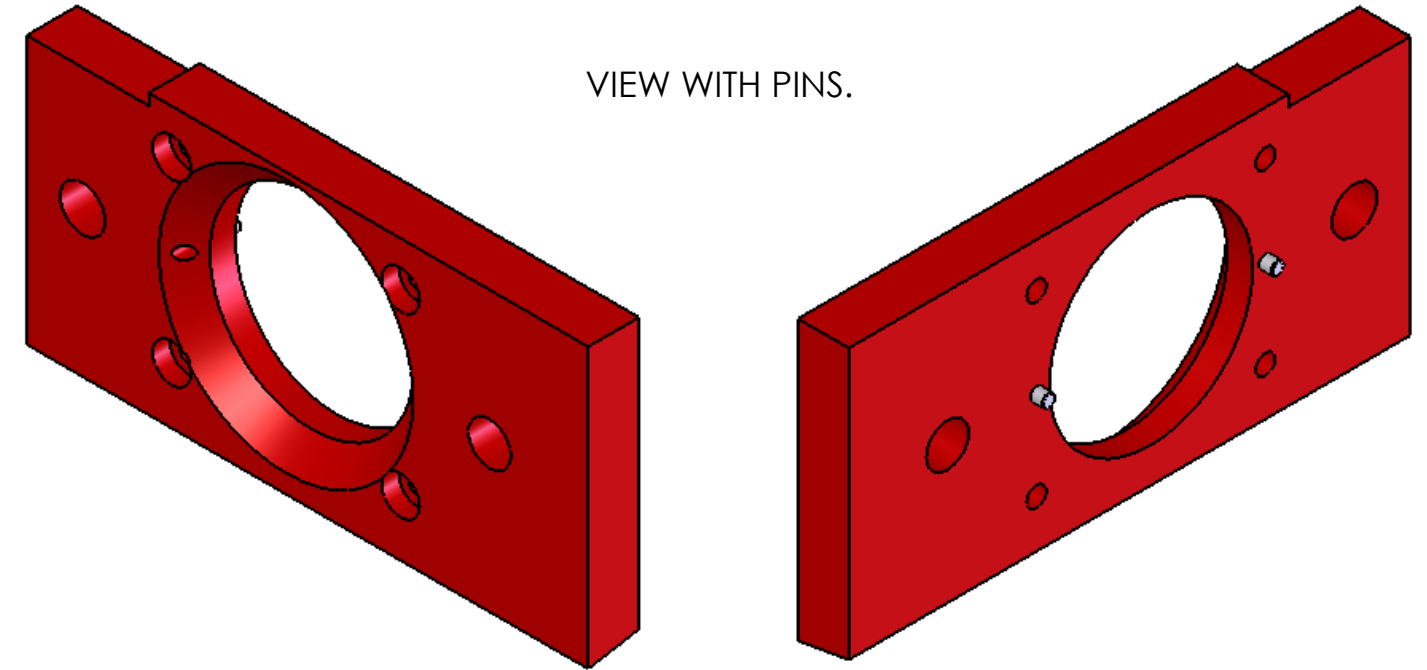

VIEW WITH PINS.

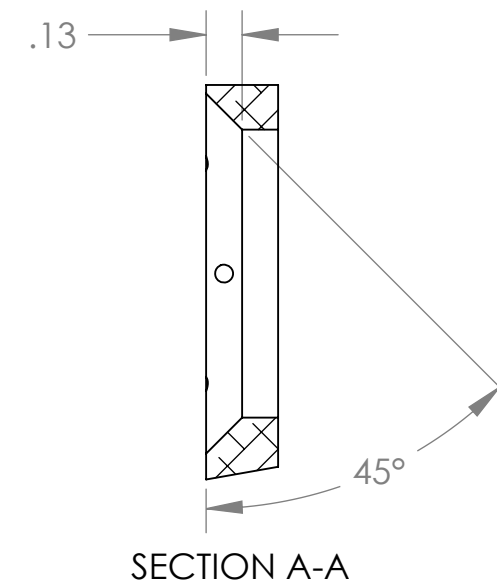
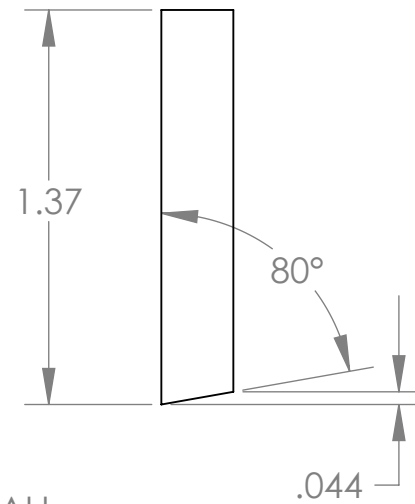
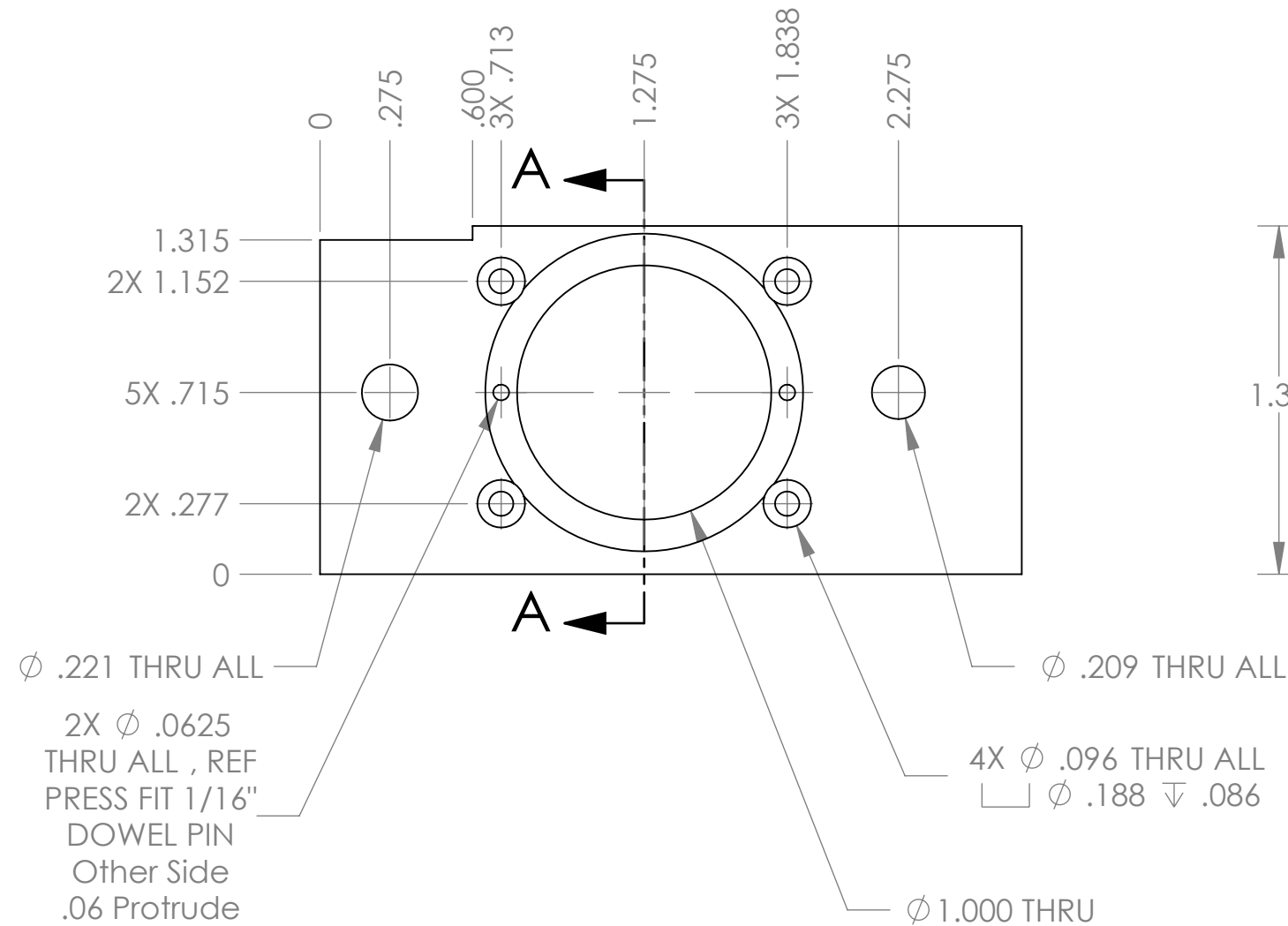

UNLESS OTHERWISE SPECIFIED DIMENSIONS ARE IN INCHES, REMOVE BURRS AND BREAK SHARP EDGES 0.005-0.010

TOLERANCES: .XX ± .010 .XXX ± .005  
 ANGLES ± 0.5° UNLESS NOTED,  
 ALL SURFACES 64 UNLESS NOTED

MATERIAL: 303 STAINLESS  
 QTY: 3

NAME:	INIT.	DATE:
DRAWN:	SCP	05/10/07
CHECKED:	CH	05/14/07
APPROVED:		
FABRICATED:		
FILE: TRDOP56 Lyot Stop Plate		

**TRIPLESPEC** Cornell University  
 Center for Radiophysics and Space Research - Ithaca, NY 14853

TITLE: LYOT STOP PLATE

SIZE: B DRAWING # TRDOP56 REV 1

SCALE: 1.5:1 DATE: 5/14/2007 SHEET 1 OF 1